

NKQB24-1, NKQX24-1

On/Off, Fail-Safe, Operation, Direct Coupled, 24V



Technical Data	NKQB24-1, NKQX24-1
Power supply	24VAC \pm 20% 50/60Hz 24VDC \pm 10%
Power consumption	11W (3W)
Transformer sizing	22VA (class 2 power source)
Electrical connection	18 GA plenum rated cable ½" conduit connector protected NEMA 2 (IP54) 3 ft [1m] 10 ft [3m] 16 ft [5m]
Overload protection	electronic throughout 0 to 95 rotation
Operation range Y	on/off
Input impedance	100k Ω (0.1 mA), 500 Ω 1500 Ω (PWM, on/off)
Feedback output U	2 to 10VDC, 0.5mA max, VDC variable
Angle of rotation	max. 95°, adjustable with mechanical stop electronically variable
Torque	54 in-lb [6 Nm]
Direction of rotation	reversible with switch
Fail-safe position	adjustable with dial or tool 0 to 100% in 10% increments
Position indication	reflective visual indicator (snap-on)
Manual override	external push button
Running time	normal operation 4 seconds (default), variable 4 to 16 seconds fail-safe 4 seconds
Humidity	5 to 95% RH non-condensing (EN 60730-1)
Ambient temperature	-22°F to +122°F [-30°C to +50°C]
Storage temperature	-40°F to +176°F [-40°C to +80°C]
Housing	NEMA2, IP54, UL enclosure type 2
Housing material	UL94-5VA
Agency list	cULus acc. to UL 60730-1A/-2-14 CAN/CSA E60730-1:02 CE acc. to 2004/108/EEC and 2006/95/EC
Noise level	< 60dB(A)
Servicing	maintenance free
Quality standard	ISO 9001
Weight	2.4 lbs [1.10 kg]

Torque min. 54 in-lb for control damper surfaces up to 12 sq ft.

Application

For proportional modulation of dampers in HVAC systems.

The NKQB24-1 and NKQX24-1 provide electrical power off operation for reliable fail-safe application.

The actuator is mounted directly to a damper shaft up to 1.05" in diameter. A crank arm and several mounting brackets are available for applications where actuator cannot be direct coupled to the damper shaft.

Operation

The actuator is electronically protected against overload. The anti-rotation strap supplied with the actuator will prevent lateral movement.

The NKQB24-1 and the NKQX24-1 provide 95° of rotation and a visual indicator shows the position of the actuator. When reaching the damper or actuator end position the actuator automatically stops. The gear can be manually disengaged by pressing the button located on the actuator cover.

The NKQB24-1 and NKQX24-1 actuators use a brushless DC motor controlled by an Application Specific Integrated Circuit (ASIC). The ASIC monitors and controls the actuators rotation and provides a digital rotation sensing (DRS) function to prevent damage to the actuator in a stall condition. Power consumption is reduced in a holding mode.

Add-on auxiliary switches or feedback potentiometers are easily fastened directly onto the actuator body for signaling and switching functions.

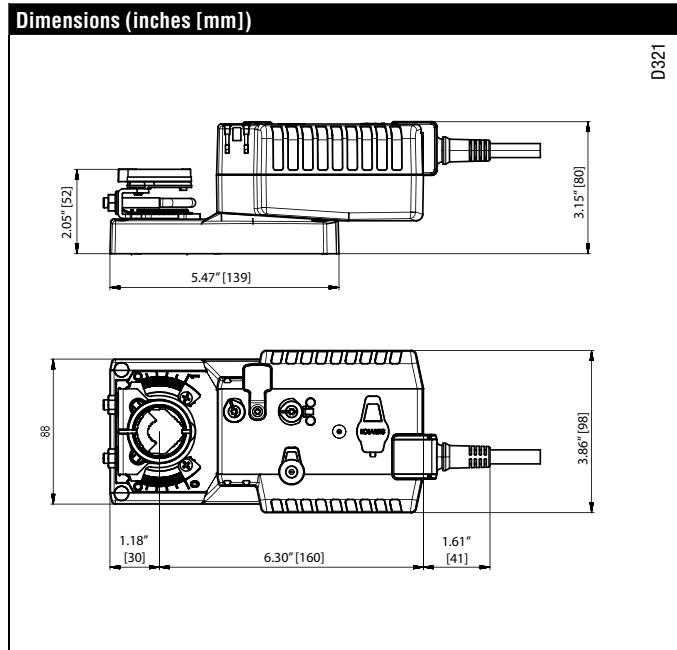

M40024 - 05/10 - Subject to change. © Belimo Aircontrols (USA), Inc.

Accessories	
K-AM25	¾" [20mm] Shaft Clamp
ZG-102	Multiple Actuator Mounting Bracket
ZG-NMA	Crank arm Adaptor Kit
ZG-JSA (-1,2,3)	Jackshaft Adaptors for Hollow Jackshafts
ZS-100	Weather Shield - Steel
ZS-150	Weather Shield - Polycarbonate
ZS-260	Explosion Proof Housing
ZS-300 (-1) (-5)	NEMA 4X Housing
Tool-06	8 and 10 mm Wrench
PS-100	Actuator Power Supply Simulator
S1A, S2A	Auxiliary Switch(es)
P370	Shaft Mount Auxiliary Switch
P...A	Feedback Potentiometers
ZG-X40	Transformer

Note: When using NKQB24-3 and NKQX24-3 actuators, only use accessories listed on this page.

Typical Specification

On/off control damper actuators shall be electronic direct-coupled type, which require no crank arm and linkage and be capable of direct mounting to shaft up to 1.05" diameter. Actuators shall have Brushless DC motor technology and be protected from overload at all angles of rotation. Actuators shall have reversing switch and manual override on the cover. Run time shall be constant and independent of torque. Actuators shall be cULus listed, have a 5-year warranty, and be manufactured under ISO 9001 International Quality Control Standards. Actuators shall be as manufactured by Belimo.

Wiring Diagrams

✂️ INSTALLATION NOTES

- 1 Provide overload protection and disconnect as required.
- 2 **CAUTION Equipment Damage!**
Actuators may be connected in parallel if not mechanically mounted to the same shaft. Power consumption and input impedance must be observed.
- 3 Actuators may also be powered by 24 VDC.
- 4 Position feedback cannot be used with Triac sink controller. The actuator internal common reference is not compatible.
- 5 Control signal may be pulsed from either the Hot (source) or the Common (sink) 24 VAC line.
- 8 Contact closures A & B also can be triacs. A & B should both be closed for triac source and open for triac sink.
- 9 For triac sink the common connection from the actuator must be connected to the hot connection of the controller.

📄 APPLICATION NOTES

- ◆ Meets UL requirements without the need of an electrical ground connection.
- ⚠️ **WARNING Live Electrical Components!**
During installation, testing, servicing and troubleshooting of this product, it may be necessary to work with live electrical components. Have a qualified licensed electrician or other individual who has been properly trained in handling live electrical components perform these tasks. Failure to follow all electrical safety precautions when exposed to live electrical components could result in death or serious injury.

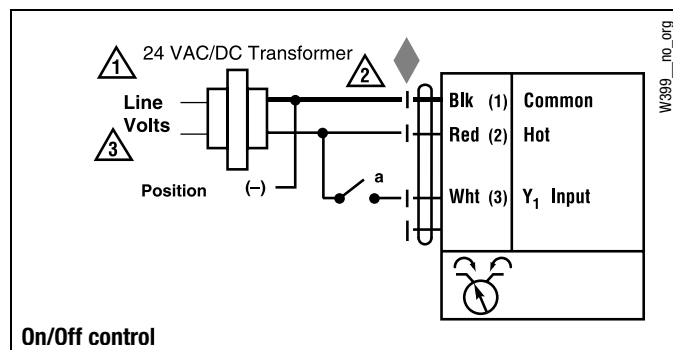

NKQB24-SR, NKQX24-SR

Proportional Control, Fail-Safe, Operation, Direct Coupled, 24V, for 2 to 10 VDC and 4 to 20mA



Technical Data	NKQB24-SR, NKQX24-SR
Power supply	24VAC \pm 20% 50/60Hz 24VDC \pm 10%
Power consumption	11W (3W)
Transformer sizing	22VA (class 2 power source)
Electrical connection	18 GA plenum rated cable $\frac{1}{2}$ " conduit connector protected NEMA 2 (IP54) 3 ft [1m] 10 ft [3m] 16 ft [5m]
Overload protection	electronic throughout 0 to 95 rotation
Operation range Y	2 to 10 VDC, 4 to 20mA (default)
Input impedance	100k Ω (0.1 mA), 500 Ω
Feedback output U	2 to 10VDC, 0.5mA max, VDC variable
Angle of rotation	max. 95°, adjustable with mechanical stop electronically variable
Torque	54 in-lb [6 Nm]
Direction of rotation	reversible with switch
Fail-safe position	adjustable with dial or tool 0 to 100% in 10% increments
Position indication	reflective visual indicator (snap-on)
Manual override	external push button
Running time	
normal operation	4 seconds (default), variable 4 to 16 seconds
fail-safe	4 seconds
Humidity	5 to 95% RH non-condensing (EN 60730-1)
Ambient temperature	-22°F to +122°F [-30°C to +50°C]
Storage temperature	-40°F to +176°F [-40°C to +80°C]
Housing	NEMA2, IP54, UL enclosure type 2
Housing material	UL94-5VA
Agency list	cULus acc. to UL 60730-1A/-2-14 CAN/CSA E60730-1:02 CE acc. to 2004/108/EEC and 2006/95/EC
Noise level	60dB(A)
Servicing	maintenance free
Quality standard	ISO 9001
Weight	2.40 lbs [1.1 kg]

Torque min. 54 in-lb for control damper surfaces up to 12 sq ft.

Application

For proportional modulation of dampers in HVAC systems.

The NKQB24-SR and NKQX24-SR provide electrical power off operation for reliable fail-safe application.

The actuator is mounted directly to a damper shaft up to 1.05" in diameter by a universal clamp. A crank arm and several mounting brackets are available for applications where actuator cannot be direct coupled to the damper shaft.

The actuator operates in response to a 2 to 10 VDC, or with the addition of a 500 Ω resistor, a 4 to 20mA control input from an electronic controller or positioner. A 2 to 10 VDC feedback signal is provided for position indication or master-slave applications.

Operation

The actuator is electronically protected against overload. The anti-rotation strap supplied with the actuator will prevent lateral movement.

The NKQB24-SR and NKQX24-SR provide 95° of rotation and a visual indicator shows the position of the actuator. When reaching the damper or actuator end position the actuator automatically stops. The gear can be manually disengaged by pressing the black button located on the actuator cover.

The NKQB24-SR and NKQX24-SR actuators use a brushless DC motor, which is controlled by an Application Specific Integrated Circuit (ASIC). The ASIC monitors and controls the actuators rotation and provides a digital rotation sensing (DRS) function to prevent damage to the actuator in a stall condition. Power consumption is reduced in a holding mode.

Add-on auxiliary switches or feedback potentiometers are easily fastened directly onto the actuator body for signaling and switching functions.

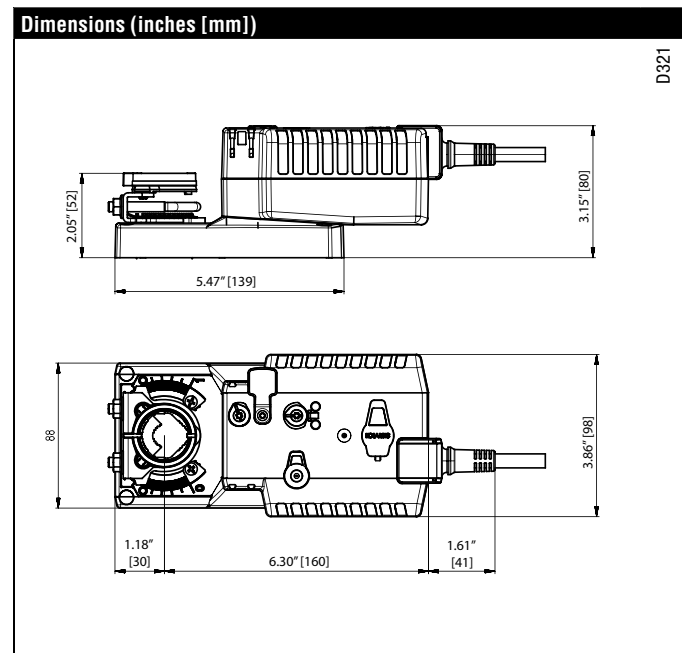

M40024 - 05/10 - Subject to change. © Belimo Aircontrols (USA), Inc.

Accessories

K-AM25	3/4" [20mm] Shaft Clamp
ZG-102	Multiple Actuator Mounting Bracket
ZG-NMA	Crank arm Adaptor Kit
ZG-JSA (-1,2,3)	Jackshaft Adaptors for Hollow Jackshafts
ZS-100	Weather Shield - Steel
ZS-150	Weather Shield - Polycarbonate
ZS-260	Explosion Proof Housing
ZS-300 (-1) (-5)	NEMA 4X Housing
Tool-06	8 and 10 mm Wrench
PS-100	Actuator Power Supply Simulator
S1A, S2A	Auxiliary Switch(es)
P370	Shaft Mount Auxiliary Switch

Note: When using NKQB24-SR and NKQX24-SR actuators, only use accessories listed on this page.

Typical Specification

Proportional control damper actuators shall be electronic direct-coupled type, which require no crank arm and linkage and be capable of direct mounting to shaft up to 1.05" diameter. Actuators must provide proportional damper control response to a 2 to 10 VDC or, with the addition of a 500Ω resistor, a 4 to 20 mA control input from an electronic controller or positioner. Actuators shall have brushless DC motor technology and be protected from overload at all angles of rotation. Actuators shall have reversing switch and manual override on the cover. Run time shall be constant and independent of torque. Actuators shall be cULus listed, have a 5-year warranty, and be manufactured under ISO 9001 International Quality Control Standards. Actuators shall be as manufactured by Belimo.

Electrical Installation

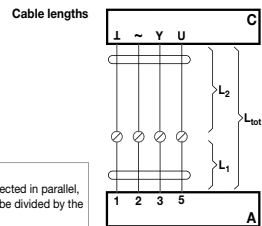
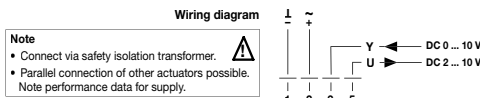

Note
When several actuators are connected in parallel, the maximum cable length must be divided by the number of actuators.

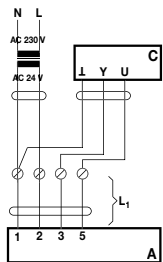

Note
There are no special restrictions on installation if the supply and data cable are routed separately.

Cable colors:
1 = black
2 = red
3 = white
5 = orange

A = Actuator
C = Control unit
L₁ = Belimo connecting cable, 1 m (4 x 0.75 mm²)
L₂ = Customer cable
L_{tot} = Maximum cable length

Cross section L ₂ l / ~	Max. cable length L _{tot} = L ₁ + L ₂		Example for DC
	AC	DC	
0.75 mm ²	≤30 m	≤5 m	1 m (L ₁) + 4 m (L ₂)
1.00 mm ²	≤40 m	≤8 m	1 m (L ₁) + 7 m (L ₂)
1.50 mm ²	≤70 m	≤12 m	1 m (L ₁) + 11 m (L ₂)
2.50 mm ²	≤100 m	≤20 m	1 m (L ₁) + 19 m (L ₂)

A = Actuator
C = Control unit
L₁ = Belimo connecting cable, 1 m (4 x 0.75 mm²)

Wiring Diagrams

INSTALLATION NOTES

- Provide overload protection and disconnect as required.
- CAUTION Equipment Damage!**
Actuators may be connected in parallel if not mechanically mounted to the same shaft. Power consumption and input impedance must be observed.
- Actuators may also be powered by 24 VDC.

APPLICATION NOTES

- Meets UL requirements without the need of an electrical ground connection.
- The ZG-R01 500 Ω resistor may be used.

WARNING Live Electrical Components!
During installation, testing, servicing and troubleshooting of this product, it may be necessary to work with live electrical components. Have a qualified licensed electrician or other individual who has been properly trained in handling live electrical components perform these tasks. Failure to follow all electrical safety precautions when exposed to live electrical components could result in death or serious injury.

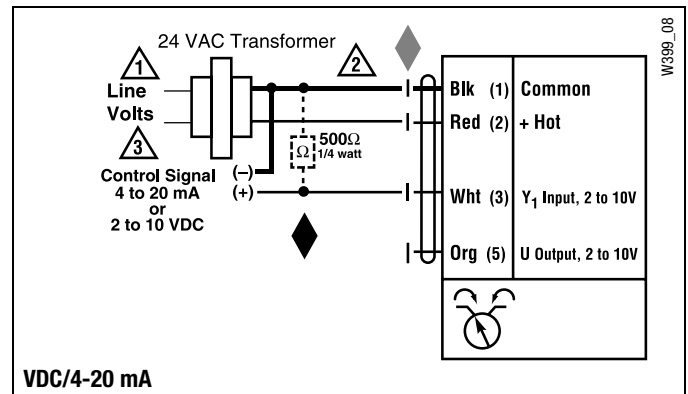



Technical Data	NKQX24-MFT
Power supply	24VAC ±20% 50/60Hz 24VDC ±10%
Power consumption	11W (3W)
Transformer sizing	22VA (class 2 power source)
Electrical connection	18 GA plenum rated cable ½" conduit connector protected NEMA 2 (IP54) 3 ft [1m] 10 ft [3m] 16 ft [5m]
Overload protection	electronic throughout 0 to 95° rotation
Operation range Y	2 to 10 VDC, 4 to 20mA (default), variable VDC
Input impedance	100kΩ (0.1 mA), 500Ω
Feedback output U	2 to 10VDC, 0.5mA max, VDC variable
Angle of rotation	max. 95°, adjustable with mechanical stop electronically variable
Torque	54 in-lb [6 Nm]
Direction of rotation	reversible with switch
Fail-safe position	adjustable with dial or tool 0 to 100% in 10% increments
Position indication	reflective visual indicator (snap-on)
Manual override	external push button
Running Time	
normal operation	4 seconds (default), variable 4 to 16 seconds
fail-safe	4 seconds
Humidity	5 to 95% RH non-condensing (EN 60730-1)
Ambient temperature	-22°F to +122°F [-30°C to +50°C]
Storage temperature	-40°F to +176°F [-40°C to +80°C]
Housing	NEMA2, IP54, UL enclosure type 2
Housing material	UL94-5VA
Agency list	cULus acc. to UL 60730-1A/-2-14 CAN/CSA E60730-1:02 CE acc. to 2004/108/EEC and 2006/95/EC
Noise level	60dB(A)
Servicing	maintenance free
Quality standard	ISO 9001
Weight	2.40 lbs [1.1 kg]

Torque min. 54 in-lb for control damper surfaces up to 12 sq ft.

Application

For proportional modulation of dampers in HVAC systems.

The NKQX24-MFT provides electrical power off operation for reliable fail-safe application.

The actuator is mounted directly to a damper shaft up to 1.05" in diameter by a universal clamp. A crank arm and several mounting brackets are available for applications where actuator cannot be direct coupled to the damper shaft.

The default parameters for 2 to 10 VDC applications of the NKQX24-MFT actuator are assigned during manufacturing. If necessary, custom versions of the actuator can be ordered. The parameters can be changed by: pre set or custom configurations provided by Belimo or on-site using the PC-Tool software.

Operation

The actuator is electronically protected against overload. The anti-rotation strap supplied with the actuator will prevent lateral movement.

The NKQX24-MFT provides 95° of rotation and a visual indicator shows the position of the actuator. When reaching the damper or actuator end position the actuator automatically stops. The gear can be manually disengaged by pressing the button located on the actuator cover.

The NKQX24-MFT actuator uses a brushless DC motor, which is controlled by an Application Specific Integrated Circuit (ASIC). The ASIC monitors and controls the actuators rotation and provides a digital rotation sensing (DRS) function to prevent damage to the actuator in a stall condition. Power consumption is reduced in a holding mode.

Add-on auxiliary switches or feedback potentiometers are easily fastened directly onto the actuator body for signaling and switching functions.

When combining signal and power cable together, see important electrical installation diagram on page 164.

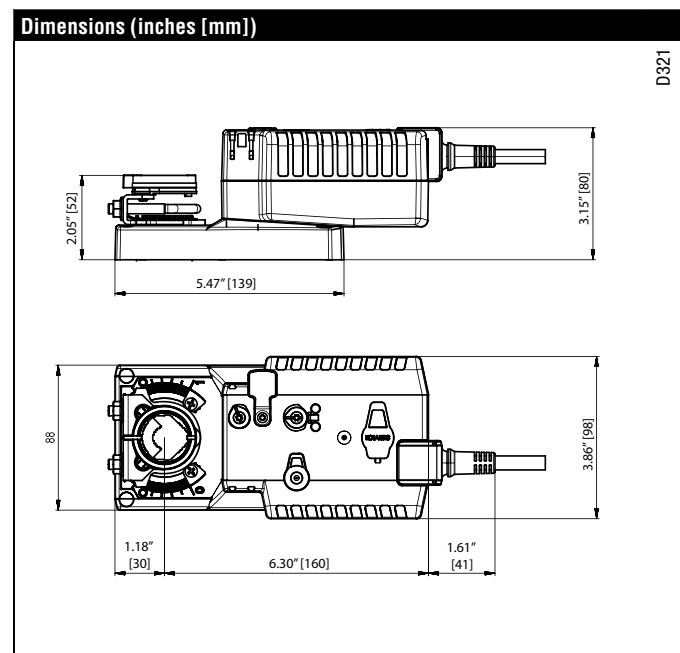

M40024 - 05/10 - Subject to change. © Belimo Aircontrols (USA), Inc.

Accessories

K-AM25	3/4" [20mm] Shaft Clamp
ZG-102	Multiple Actuator Mounting Bracket
ZG-NMA	Crank arm Adaptor Kit
ZG-JSA (-1,2,3)	Jackshaft Adaptors for Hollow Jackshafts
ZS-100	Weather Shield - Steel
ZS-150	Weather Shield - Polycarbonate
ZS-260	Explosion Proof Housing
ZS-300 (-1) (-5)	NEMA 4X Housing
Tool-06	8 and 10 mm Wrench
PS-100	Actuator Power Supply Simulator
S1A, S2A	Auxiliary Switch(es)
P370	Shaft Mount Auxiliary Switch
P...A	Feedback Potentiometers
SGA24	Min positioners in NEMA 4 Housing
SGF24	Min positioners for flush panel mounting
ADS-100	Analog to Digital Switch
ZG-R01	Resistor for 4 to 20 mA Conversion
NSV24 US	Battery Back-Up Module
ZG-X40	Transformer

Note: When using NKQX24-MFT actuators, only use accessories listed on this page.

Typical Specification

Proportional control damper actuators shall be electronic direct-coupled type, which require no crank arm and linkage and be capable of direct mounting to shaft up to 1.05" diameter. Actuators must provide proportional damper control response to a 2 to 10 VDC or, with the addition of a 500Ω resistor, a 4 to 20 mA control input from an electronic controller or positioner. Actuators shall have brushless DC motor technology and be protected from overload at all angles of rotation. Actuators shall have reversing switch and manual override on the cover. Run time shall be constant and independent of torque. Actuators shall be cULus listed, have a 5-year warranty, and be manufactured under ISO 9001 International Quality Control Standards. Actuators shall be as manufactured by Belimo.

Wiring Diagrams

INSTALLATION NOTES

- 1 Provide overload protection and disconnect as required.
- 2 **CAUTION Equipment Damage!** Actuators may be connected in parallel if not mechanically mounted to the same shaft. Power consumption and input impedance must be observed.
- 3 Actuators may also be powered by 24 VDC.
- 4 Position feedback cannot be used with Triac sink controller. The actuator internal common reference is not compatible.
- 5 Control signal may be pulsed from either the Hot (source) or the Common (sink) 24 VAC line.
- 8 Contact closures A & B also can be triacs. A & B should both be closed for triac source and open for triac sink.
- 9 For triac sink the common connection from the actuator must be connected to the hot connection of the controller.

APPLICATION NOTES

- Meets UL requirements without the need of an electrical ground connection.

The ZG-R01 500 Ω resistor may be used.



WARNING Live Electrical Components!

During installation, testing, servicing and troubleshooting of this product, it may be necessary to work with live electrical components. Have a qualified licensed electrician or other individual who has been properly trained in handling live electrical components perform these tasks. Failure to follow all electrical safety precautions when exposed to live electrical components could result in death or serious injury.

